

## *Signs*

Please refer to the "Sign Placement Diagram" at the end of this document for the placement of all types of signs.

### *For Sale or Lease and Open House Signs*

The installation of **one** For Sale (or Lease) sign that represents a real estate agency and/or Homeowner will be permitted at the front (street side) of a residence. The sign is to be placed on the yard of the residence and not fastened to the building. In areas where signs must be placed in the common areas, the sign is to be placed as close as possible to the home and not near the curbs or street.

Such signs placed by real estate agencies shall not exceed 5 ft. in height (including posts or stands) and must be neat and professional in appearance. Signs may include receptacles which hold information regarding features of the home; however such receptacles cannot exceed dimensions of approximately 14 in. deep x 8 in. wide x 10 in. high, and shall be included as part of the dimensions of the sign.

Westbrook Village Association has available, for a deposit and a small rental fee, standardized For Sale or Lease and Open House signs for homes that are offered for sale by owner.

A maximum of 4 open house temporary signs used for the purpose of directing persons to a home for sale in the Village are permitted.

**Placement of signs (other than for association events) shall not be on any street or island, any main entrance to Westbrook Village, create a traffic hazard or block any sidewalk. WVA will pick up incorrectly placed signs.** The signs may be in place during daylight hours and must be removed by dusk. For Sale signs must be removed from in front of the home the day after close of escrow.

### *Garage Sale Signs*

Westbrook Village Association has available for a deposit standardized Garage Sale signs for use by homeowners. Signs can be obtained at the Lakes Recreation Center Office. **Placement of signs (other than for association events) shall not be on any street or island, any main entrance to Westbrook Village, create a traffic hazard or block any sidewalk. WVA pick up incorrectly placed signs and the deposit will be forfeited.**

Garage sale signs may be in place during daylight hours and must be removed by dusk.

### *Political Signs*

- Political signs may be displayed on private property per State of Arizona law and in accordance with the City of Peoria sign ordinance.
- Political signs are only permitted during the election period and must be removed within 2 days after the election.

## Sign Placement Diagram

Including Garage / Yard Sale, Estate Sale, For Sale, Open House, For Rent

### RESIDENTIAL STREETS

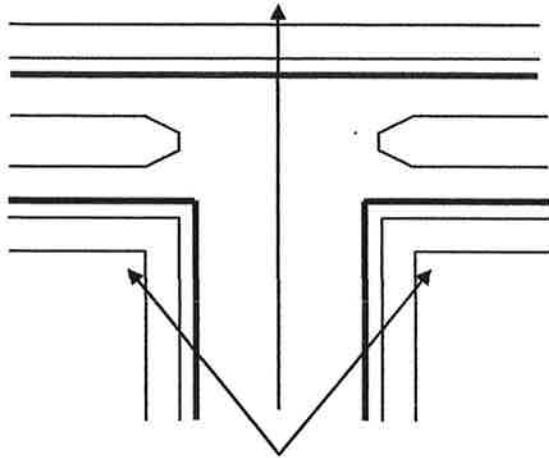

Place signs behind sidewalk ONLY

### RESIDENTIAL INTERSECTIONS

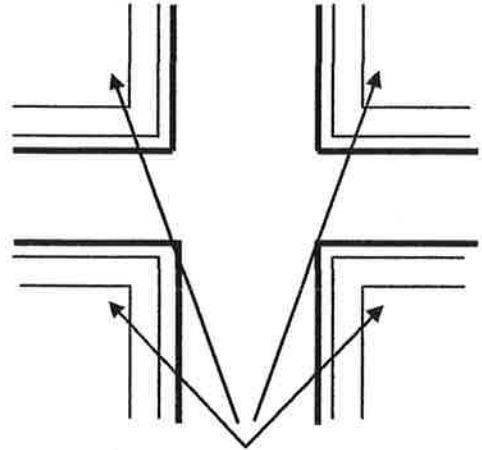

Place signs behind sidewalk ONLY

## DO NOT PLACE ANY SIGNS AT THE FOLLOWING LOCATIONS

### GOLF COURSE OR REC CENTER PROPERTY

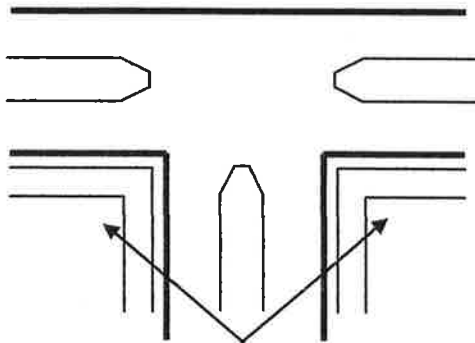

Place signs ONLY at corners Across from these Areas behind sidewalk

### WESTBROOK ENTRANCES

NORTH SIDE OF UNION HILLS

WEST SIDE OF 83<sup>RD</sup> AVE.

SOUTH SIDE OF BEARDSLEY ROAD

EAST or WEST SIDE OF 91<sup>ST</sup> AVE.

ON THE SIDEWALK, ROADWAY, OR CENTER ISLAND

The City of Peoria does not allow placement of signs on the street, sidewalk or on a center island